



In-Flight Safety Monitoring System

The In-Flight Safety Monitoring System (ISMS™) is a data acquisition and transmission system designed by Star Navigation and hosted on the JetLAN Airborne Server Unit. The complete system is comprised of a JetLAN Server running the ISMS™ Software, Satcom receiver / transmitter, an antenna and associated cabling with no interference to the cockpit.



The system performs data acquisition of the following functions:

- flight parameters such as airspeed, heading, pitch and roll
- engine data and position information from the on-board Flight Data Recorder (FDR)
- position reporting, destination information and OIOI from the Flight Management System (FMS)
- cabin and cockpit information from the Air Data System

All of these functions are transmitted to the JetLAN through the ARINC 429 or ARINC 573 / 717 data busses and decoded with ISMS™ software.

These parameters are transmitted to remote ground-based receivers via the Iridium satellite network as suggested by the transceiver unit. The data can include active parameters, plus any historic parameters not received. This allows remote station access to and storage of an aircraft's essentially real-time activities, without the need for conventional Flight Data Recorder downloads.

Since satellites may be occasionally masked by the earth at high latitudes, the system will have the ability to store several hours of data, for transmission when the aircraft returns to operation within satellite coverage.

This mechanism also ensures that data which may "drop-out" will also be re-transmitted until confirmed as received by a ground station.

The ISMS' real-time capability to track performance-trends and predict incident - occurrence enhances aviation safety and improves fleet management while dramatically reducing operating and maintenance costs.

FEATURES:

- Proactive System Prevents Accidents
- Gives Maintenance Alerts
- Provides End-of-Flight Reports
- Customizable for Specific Airline Needs
- Collects Real-Time Data From the Aircraft's Operating Systems
- Signals Alerts on Performance Variances
- Acts as an Early Warning System

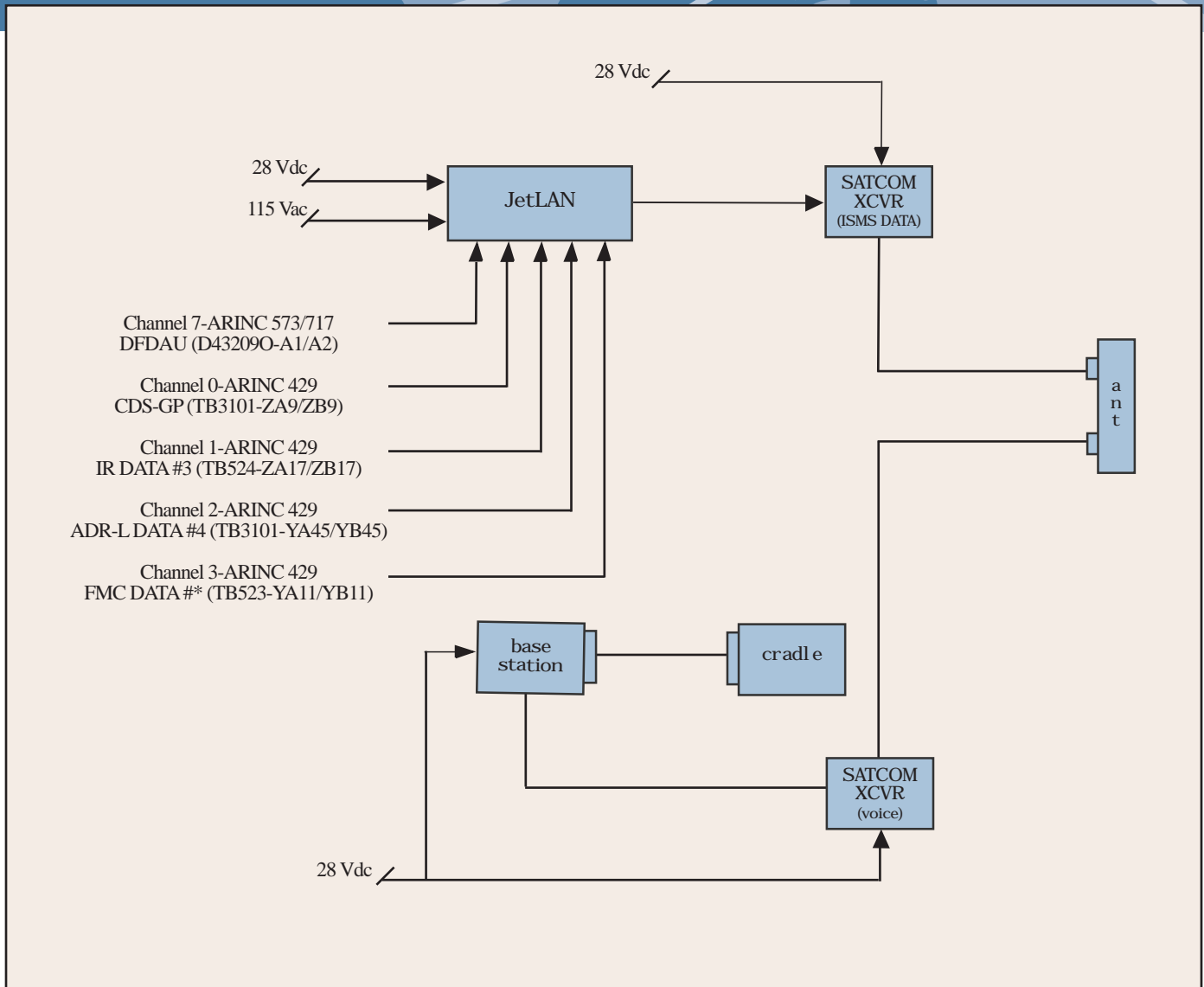

ISMS™ Early Warning System

With ISMS™ on board, every operating system on the aircraft is in “live” communication with ground control, continuously from preflight to docking at the destination terminal. Among other complex parameters, the in-flight safety monitoring system is calibrated to continually search for and detect any performance variance from the manufacturer and the airline/operator performance norms and in comparison to the aircraft’s prior flights. This capability means that ISMS™ acts as an early warning system, detecting the earliest signs of potential problems. Whereas existing aircraft monitoring systems operate on a “red” alert system – that is, signaling full-blown problems requiring immediate reaction, the ISMS™ is more a “yellow” or caution alert – flagging problem-potential, and allowing preventative maintenance on the ground; or expert, informed and proactive support for pilots on in-flight incidents. The critical value is that ISMS™ can pre-empt disaster.